

Fast RFID "The Real RFID Guys"  
36460 US Hwy 19 N  
Palm Harbor, FL 34684  
Phone: 727-772-1584  
Fax: 727-784-RFID



## INVENTORY TRACKING POLYMER COMPOSITE STAPLES



**SH/08-100RF US**  
(902-928 MHz)

**SH/08-100RF EU**  
(864-869 MHz)

**Packaging:**  
250 tags per box  
8 boxes per case

1"  
(25 mm)  
Length

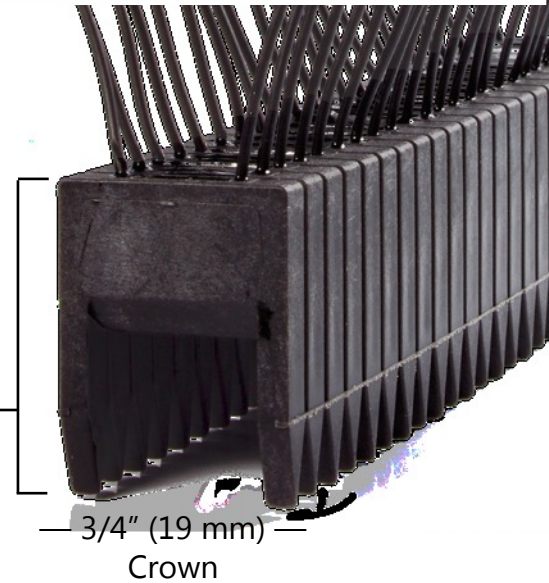

### APPLICATIONS

- Log tagging and tracking
- Pallet tagging and tracking
- Utility pole marking
- Railroad Tie Marking



### BENEFITS

- Eliminate labor for reading tags
- Instantly read multiple tags
- Real time inventory
- Reduce inventory losses



### FEATURES

- Aerospace grade polymer composite
- Will not trip metal detector
- Rugged & flexible
- UHF radio frequency ID
- Able to attach to rough wood
- Manual or pneumatic installation
- High read range (distance, angle)



### Embedded microchip

128 Bits EPC Memory  
32 Bits User Memory

# Required Tools

## HT-RFID

### Manual Hammer Tacker

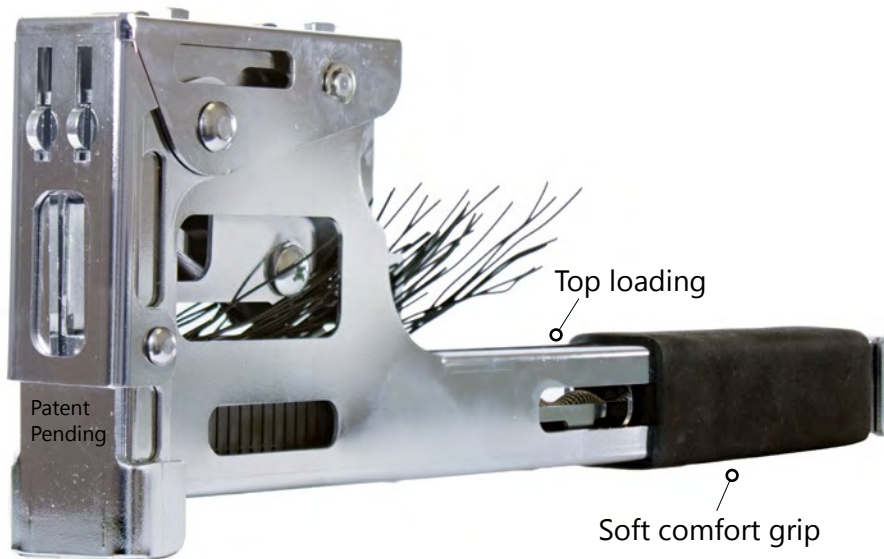

#### Technical Data

Model No.	HT-RFID
Capacity	25 tags
Weight	3.75 lbs (1.7 kg)
Dimensions (LxWxH)	14.5" x 1.75" x 5.19" (368 x 44 x 127 mm)

## OMER RFID.25

### Pneumatic

360° adjustable exhaust



#### Technical Data

Model No.	RFID.25
Capacity	50 tags
Weight	5 lbs (2.27 kg)
Dimensions (LxWxH)	15.1" x 3" x 9.6" (384 x 77 x 243 mm)
PSI	70 -100 psi 5 - 7 bar
Safety	Contact



Fast RFID "The Real RFID Guys"  
36460 US Hwy 19 N  
Palm Harbor, FL 34684

Phone: 727-772-1584  
Fax: 727-784-RFID  
www.FastRFID.com